



▪ QUICK SELECTION / Selezione veloce

input speed (n_1) = 1400 min⁻¹

Output Speed n_2 [min ⁻¹]	Ratio i	Motor power P_{1M} [kW]	Output torque M_{2M} [Nm]	Service factor f.s.	Nominal power P_{1R} [kW]	Nominal torque M_{2R} [Nm]	Available B5 motor flanges				Available B14 motor flanges			Output Shaft 	Ratios code	
							-B	-C	-D	-E	-Q	-R	-T			
							63	71	80	90	71	80	90			
891	1.57	1.5	16	1.3	1.9	20	B				C	C		2844	standard ø19 On request ø14 ø24	01
493	2.84	1.5	28	1.2	1.8	35	B				C	C		1954		02
425	3.29	1.5	33	1.2	1.7	38	B				C	C		1756		03
362	3.87	1.5	39	1.0	1.5	40	B				C	C		1558		04
303	4.62	1.5	46	1.0	1.5	47	B				C	C		1360		05
222	6.30	1.1	46	1.0	1.1	46	B				C	C		1063		06
170	8.22	0.55	30	1.3	0.69	38	B				C	C		974		07
129	10.86	0.37	27	1.0	0.39	28	B				C	C		776		08

The dynamic efficiency is 0.98 for all ratios

Motor Flanges Available
Flange Motore Disponibili

B) Supplied with Reduction Bushing
Fornito con Bussola di Riduzione

B) Available on Request without reduction bushing
Disponibile a Richiesta senza Bussola di Riduzione

C) Motor Flange Holes Position
Posizione Fori Flangia Motore

4

EN Unit 411A is supplied with synthetic oil for lifetime lubrication, no maintenance is necessary. See table 1 for lubrication and recommended quantity. In table 2 please see possible radial loads and axial loads on the gearbox.

I Il riduttore 411A viene fornito completo di olio sintetico per la lubrificazione permanente e non necessita di alcuna manutenzione. Vedi tab.1 per oli e quantità consigliati. In tab.2 sono presenti i carichi radiali e assiali applicabili al riduttore.

D Das Getriebe 411A ist mit synthetischem Öl gefüllt und ist lebensdauer geschmiert. In Tabelle 1 ist die Schmiermenge und das empfohlene Schmiermittel angegeben. In Tabelle 2 sind die zulässigen Radial - und Axialbelastungen des Getriebes aufgeführt.

F Le réducteur 411A est fourni complet avec de l'huile synthétique pour la lubrification permanente et ne nécessite aucun entretien. Voir tableau 1 concernant les huiles et les quantités conseillées. Les charges radiales et axiales applicables au réducteur sont précisées dans le tableau 2.

E El reductor tamaño 411A se suministra, lubricado de por vida con aceite sintético y no requieren mantenimiento alguna. Ver tabla 1, para cantidades y aceites recomendados. En la tabla 2, se encuentran las cargas radiales y axiales admitidas por el reductor.

▪ LUBRICATION 411A Oil Quantity 0.10 Lt.

SHELL Omala S4 WE 320

ENI Telium VSF 320

For all details on lubrication and plugs check our website **tab. 1**
Per maggiori dettagli su lubrificazione e tappi olio vedi il nostro sito web

RADIAL AND AXIAL LOADS

Output shaft

Albero di uscita

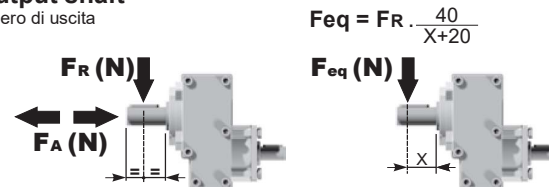

n_2	FA	FR	n_2	FA	FR	n_2	FA	FR
700	182	910	400	230	1150	200	290	1450
600	200	1000	300	250	1250	140	320	1600

Input shaft

Albero in entrata

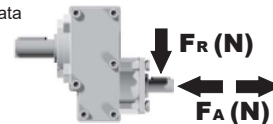

n_1	FA	FR
1400	240	1200
900	280	1400

tab. 2

P411-F ... Output flange
flange di uscita

Gearbox weight
peso riduttore **3.20 kg**

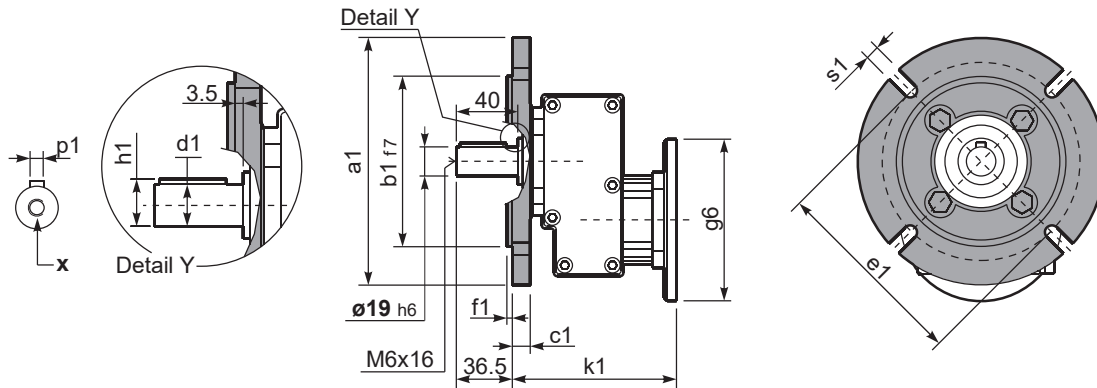

***Available output shaft / Albero di uscita**

	Shaft - d1	p1	h1	x
Standard	∅ 19x40	6	21.5	M6x16
On request A richiesta	∅ 14x30 ∅ 24x40	5 8	16 27	M5x13 M6x16

Available output flanges / flange di uscita

a1 ∅	b1	c1	e1	f1	s1	kit code
120	80	11.5	100	3	9*	KC30.9.010
140	95	11.5	115	3	9	KC30.9.011
160	110	11.5	130	3.5	9	KC30.9.012
200	130	11.5	165	3.5	11	KC30.9.013

*Holes position
posizione fori

P411-H1 ... With feet
Con piedini

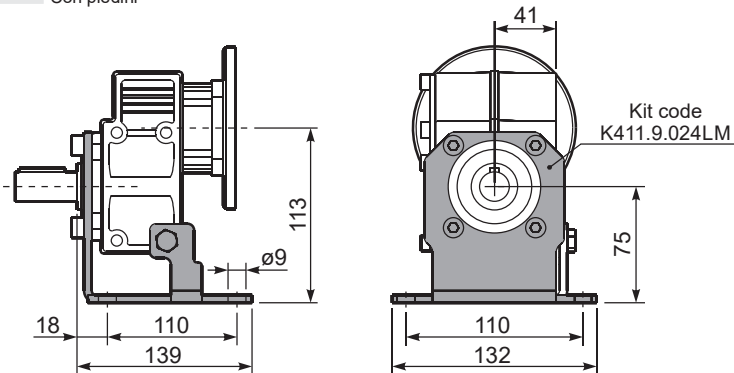

R411-N... Input Shaft
Albero in entrata

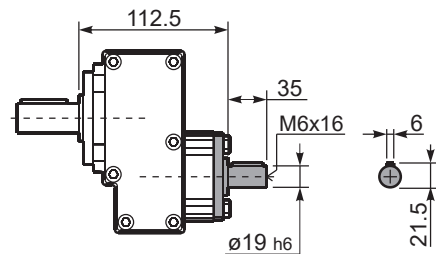

P411-N... Basic gearbox
Riduttore base

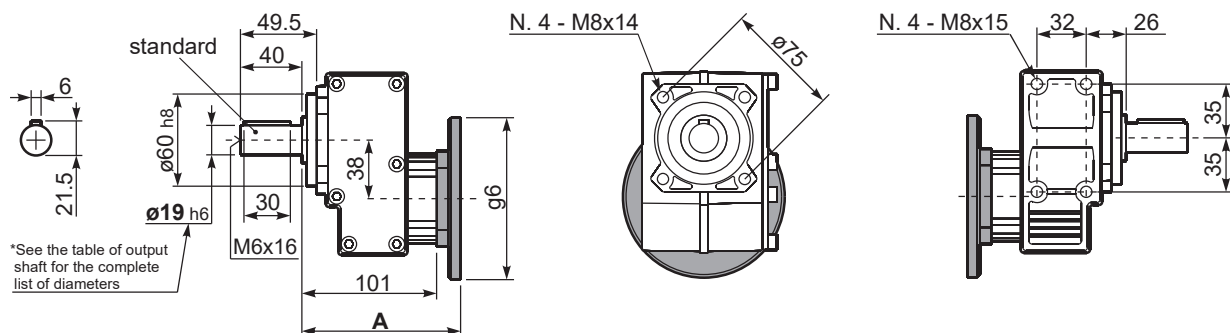

*See the table of output shaft for the complete list of diameters

B5 Motor Flanges	A	g6	k1	kit code
63 B5	121.5	140	125	K063.4.041
71 B5	119.5	160	123	K063.4.042
80/90 B5	121.5	200	125	K063.4.043

B14 Motor Flanges	A	g6	k1	kit code
71 B14	119.5	105	123	K063.4.047
80 B14	121.5	120	125	K063.4.046
90 B14	121.5	140	125	K063.4.041