

DE	PRODUKTE	EN	PRODUCTS	IT	PRODOTTI
FR	PRODUITS	ES	PRODUCTOS		

**A... / MOTOR**

**Fußbefestigung** / Foot mounting / Fissaggio piede /  
Fixation à pattes / Fijación por patas

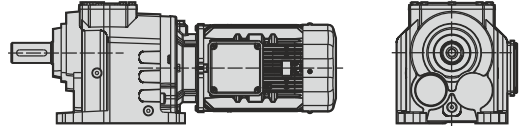

**A... / PAM**

**Fußbefestigung** / Foot mounting / Fissaggio piede /  
Fixation à pattes / Fijación por patas

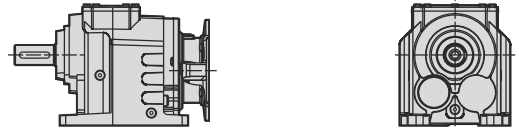

**A... / W**

**Fußbefestigung** / Foot mounting / Fissaggio piede /  
Fixation à pattes / Fijación por patas

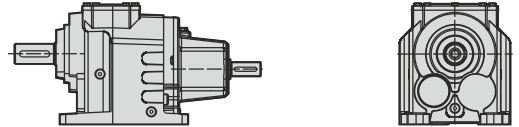

**F... / MOTOR**

**Flanschbefestigung** / Flange mounting / Fissaggio flangia /  
Fixation à bride / Fijación por brida

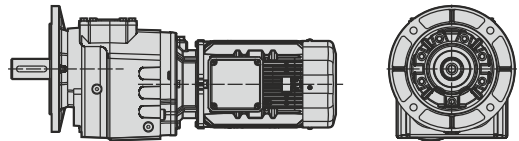

**F... / PAM**

**Flanschbefestigung** / Flange mounting / Fissaggio flangia /  
Fixation à bride / Fijación por brida

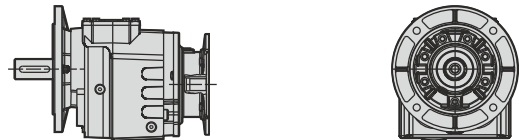

**F... / W**

**Flanschbefestigung** / Flange mounting / Fissaggio flangia /  
Fixation à bride / Fijación por brida

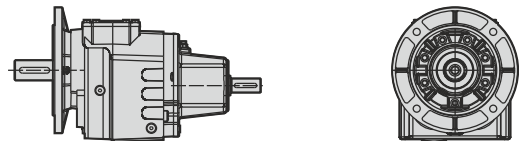

**AF... / MOTOR**

**Fuß-Flanschbefestigung** / Foot-flange mounting / Fissaggio piede-flangia  
Fixation à paaes et bride / Fijación patas-brida

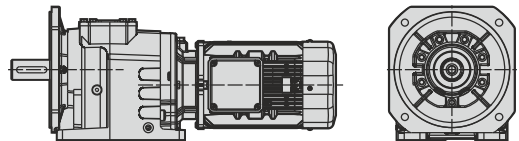

**AF... / PAM**

**Fuß-Flanschbefestigung** / Foot-flange mounting / Fissaggio piede-flangia  
Fixation à paaes et bride / Fijación patas-brida

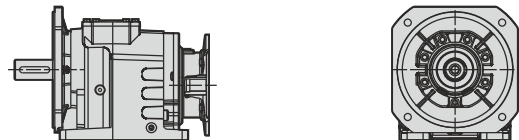

**AF... / W**

**Fuß-Flanschbefestigung** / Foot-flange mounting / Fissaggio piede-flangia  
Fixation à paaes et bride / Fijación patas-brida

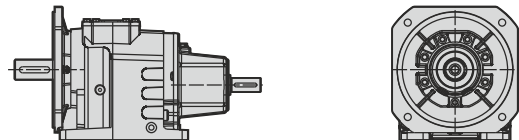

Typ / Type / Tipo Type / Tipo	l <sub>ges</sub>	4-pol 50Hz 1400rpm n <sub>2</sub> [min <sup>-1</sup> ]	M <sub>amax</sub> f <sub>B</sub> =1 4 - pol. [Nm]	W			IEC - PAM								
				P <sub>1max</sub> 4 - pol. 1400 rpm [kW]	FR1 [kN]	FR2 (a) [kN]	f <sub>B</sub> ⇨  49 - 112								
<b>A403</b>	267.75	5.2	850	0.47	2.8	12.0	71	80*	90*						
<b>F403</b>	234.50	6.0	850	0.53	2.8	12.0	71	80*	90*						
<b>W</b>	215.01	6.5	850	0.58	2.8	12.0	71	80*	90*						
	186.14	7.5	850	0.67	2.7	12.0	71	80*	90*	100*	112*				
131	170.55	8.2	850	0.73	2.7	12.0	71	80*	90*						
<b>+</b>	149.47	9.4	850	0.83	2.7	12.0	71	80	90*	100*	112*				
<b>PAM - IEC</b>	135.37	10.3	850	0.92	2.7	12.0	71	80	90*	100*	112*				
	118.13	11.9	850	1.05	2.7	12.0	71	80	90*	100*	112*				
131	94.86	14.8	850	1.31	2.7	12.0	71	80	90*	100*	112*				
	85.91	16.3	850	1.45	2.6	12.0	71	80	90*	100*	112*				
	68.25	20.5	850	1.83	2.6	12.0		80	90	100*	112*				
	54.81	25.5	850	2.27	2.5	12.0		80	90	100*	112*				
	49.64	28.2	850	2.51	2.5	12.0		80	90	100*	112*				
<b>A402</b>	45.38	30.9	850	2.75	2.4	12.0	80	90	100*	112*					
<b>F402</b>	39.72	35.2	850	3.14	2.4	12.0	80	90	100	112*					
<b>W</b>	36.44	38.4	800	3.22	2.4	12.0	80	90	100	112*					
	31.50	44.4	850	3.96	2.3	12.0	80	90	100	112*	132*				
131	28.89	48.5	800	4.06	2.3	12.0	80	90	100	112*					
<b>+</b>	25.30	55.3	850	4.93	2.1	12.0	80	90	100	112	132*				
<b>PAM - IEC</b>	22.91	61.1	850	5.44	2.1	12.0	80	90	100	112	132*				
	19.94	70.2	850	6.25	1.9	11.7	80	90	100	112	132*				
131	17.37	80.6	830	7.00	1.8	11.1	80	90	100	112	132*				
	16.01	87.4	800	7.33	1.8	10.8	80	90	100	112	132*				
	14.50	96.6	700	7.08	1.8	10.9	80	90	100	112	132*				
	12.44	112.5	700	8.25	1.7	10.2			100	112	132*				
	11.46	122.2	650	8.32	1.7	10.1	80	90	100	112	132*				
	9.20	152.2	600	9.56	1.5	9.4	80	90	100	112	132				
	8.33	168.0	600	10.55	1.3	9.0	80	90	100	112	132				
	7.22	193.9	550	11.17	1.3	8.7	80	90	100	112	132				
	5.80	241.5	550	13.91	0.9	7.9	80	90	100	112	132				
	5.25	266.7	500	13.96	0.9	7.8	80	90	100	112	132				
<b>A401</b>	8.25	169.7	170	3.02	2.7	3.7	80	90	100	112*					
<b>F401</b>	7.22	193.8	170	3.45	2.6	3.7	80	90	100	112*					
<b>W</b>	5.73	244.4	170	4.35	2.5	3.4	80	90	100	112*					
	5.17	271.0	170	4.82	2.5	3.2	80	90	100	112					
129	4.69	298.4	160	5.00	2.5	3.1	80	90	100	112					
<b>+</b>	3.93	355.9	150	5.59	2.4	3.0	80	90	100	112					
<b>PAM - IEC</b>	3.63	386.2	150	6.07	2.4	2.9	80	90	100	112					
	3.11	450.0	130	6.13	2.4	2.8			100	112					
129	2.52	554.7	120	6.97	2.3	2.6	80	90	100	112					
	2.08	672.0	120	8.44	2.1	2.4	80	90	100	112					
	1.31	1066.7	80	8.94	2.1	2.2	80	90	100	112					

Keine IEC - PAM-Verbindung / No IEC - PAM assembling on empty fields / Nessun assemblaggio IEC - PAM su campi vuoti / Pas d'assemblage IEC - PAM sur champs vides / Sin montaje IEC - PAM en campos vacios

63 IEC - PAM-Verbindung möglich / IEC - PAM assembling available on numbered fields / Montaggio IEC - PAM disponibile su campi numerati / Assemblage IEC - PAM disponible sur champs numérotés / Assemblage IEC - PAM disponible sur champs numérotés /

80\* Bei IEC - PAM-Verbindungen, sollten die P<sub>1max</sub>-Werte nicht überschritten werden / Do not exceed the P<sub>1max</sub> values indicated on fields with asterisk / Non superare i valori P<sub>1max</sub> indicati sui campi con l'asterisco / Ne pas dépasser les valeurs P<sub>1max</sub> indiquées sur les champs avec astérisque / No exceda los valores de P<sub>1max</sub> indicados en los campos con asterisco

**A 401**

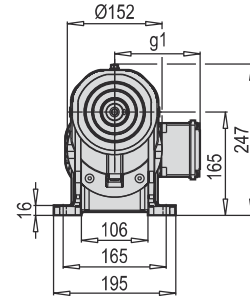
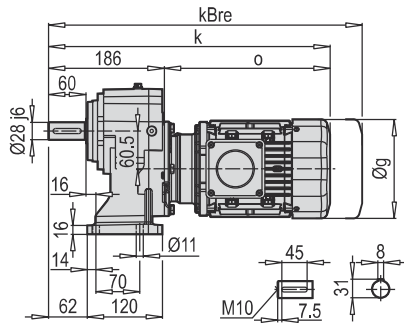

**AF-M 401**

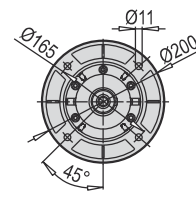
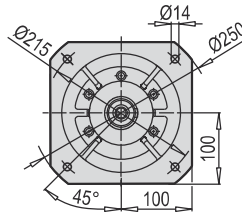
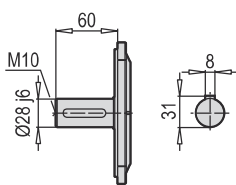
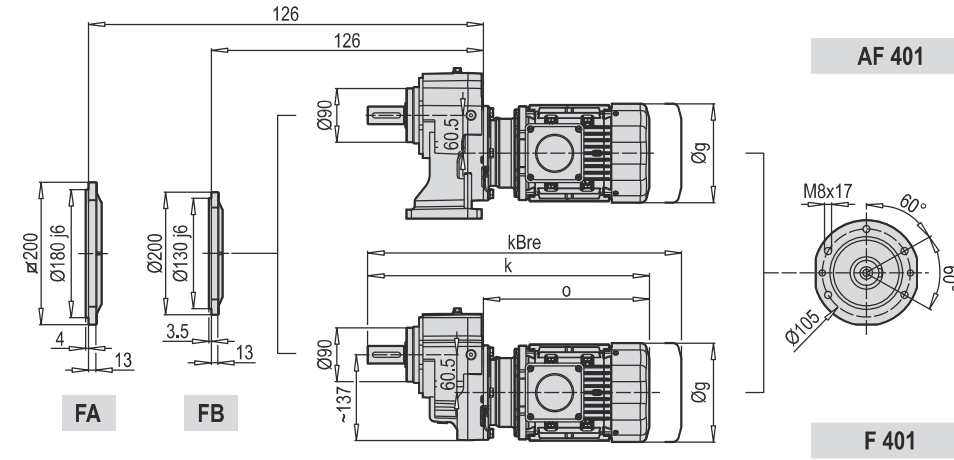
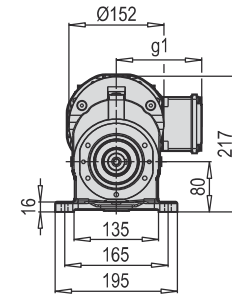
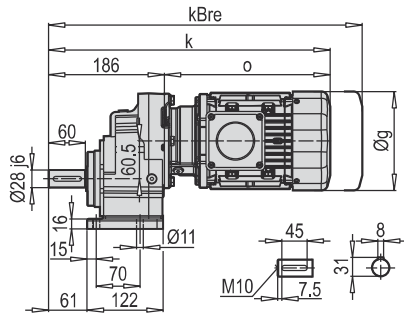

	90 S/L	100 L	112 M				
<b>g</b>	182	202	220				
<b>g1</b>	130	153	159				
<b>k</b>	534	565	569				
<b>kBre</b>	602	648	669				
<b>o</b>	348	379	383				

A 401 PAM B5/B14

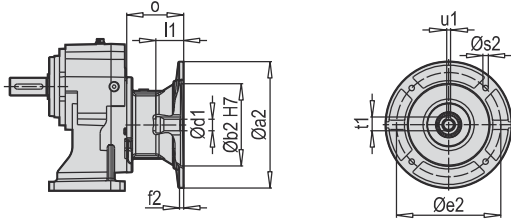

A 401 W

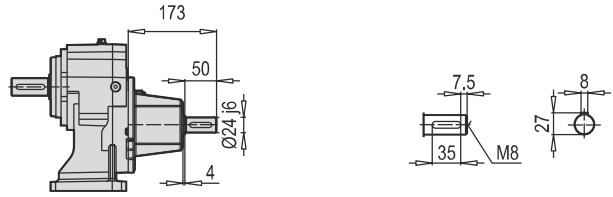

F 401 PAM B5/B14

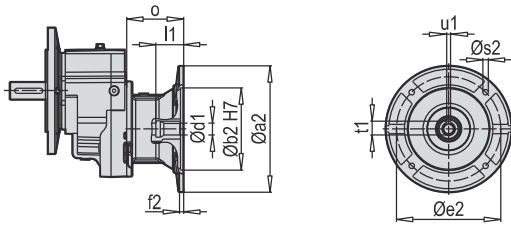

F 401 W

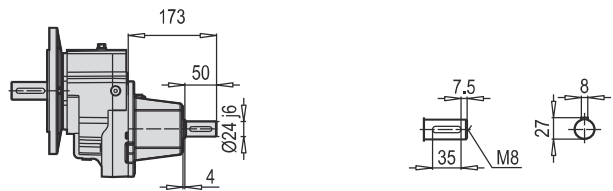

AF 401 PAM B5/B14

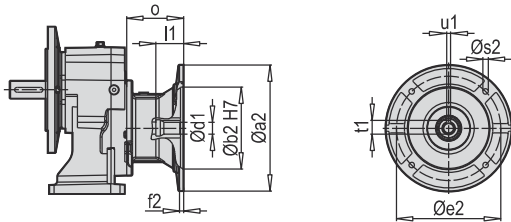

AF 401 W

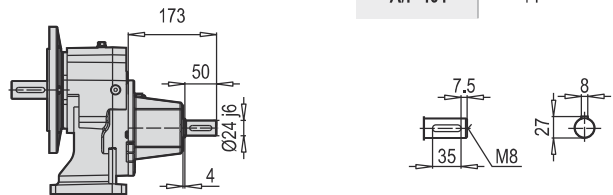

W ~ Kg	
A/F 401	14

AF-M 401 PAM B5/B14

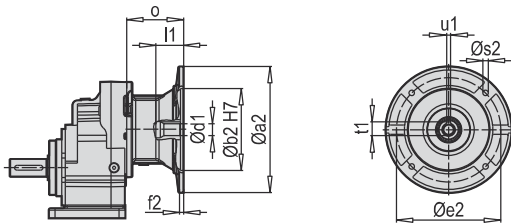

AF-M 401 W

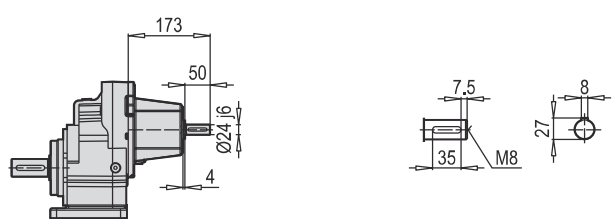

Typ / Type / Tipo Type / Tipo	PAM B5	Øa2	Øb2	Øe2	f2	Øs2	Ød1	l1	t1	u1	o
A/F 401	80	200	130	165	5	M10	19	42	21.8	6	90
	90	200	130	165	5	M10	24	52	27.3	8	90
	100	250	180	215	5.5	M12	28	62	31.3	8	105
	112	250	180	215	5.5	M12	28	62	31.3	8	105

~ Kg	
PAM B5	A/F 401
80	11
90	11
100	15.5
112	15.5

Typ / Type / Tipo Type / Tipo	PAM B14	Øa2	Øb2	Øe2	f2	Øs2	Ød1	l1	t1	u1	o
A/F 401	80	120	80	100	3	7	19	42	21.8	6	90
	90	140	95	115	3	9	24	52	27.3	8	90
	100	160	110	130	3.5	9	28	62	31.3	8	105
	112	160	110	130	3.5	9	28	62	31.3	8	105

~ Kg	
PAM B14	A/F 401
80	10
90	10
100	12
112	12

DE ALLGEMEINE TEILELISTE

EN GENERAL PART LIST

IT GENERALE ELENCO DELLE PARTI

FR GÉNÉRALE LA LISTE DES PIÈCES

ES LISTE DE PIEZAS EN GENERAL

**A / F / AF / AFM 301 ... 701**

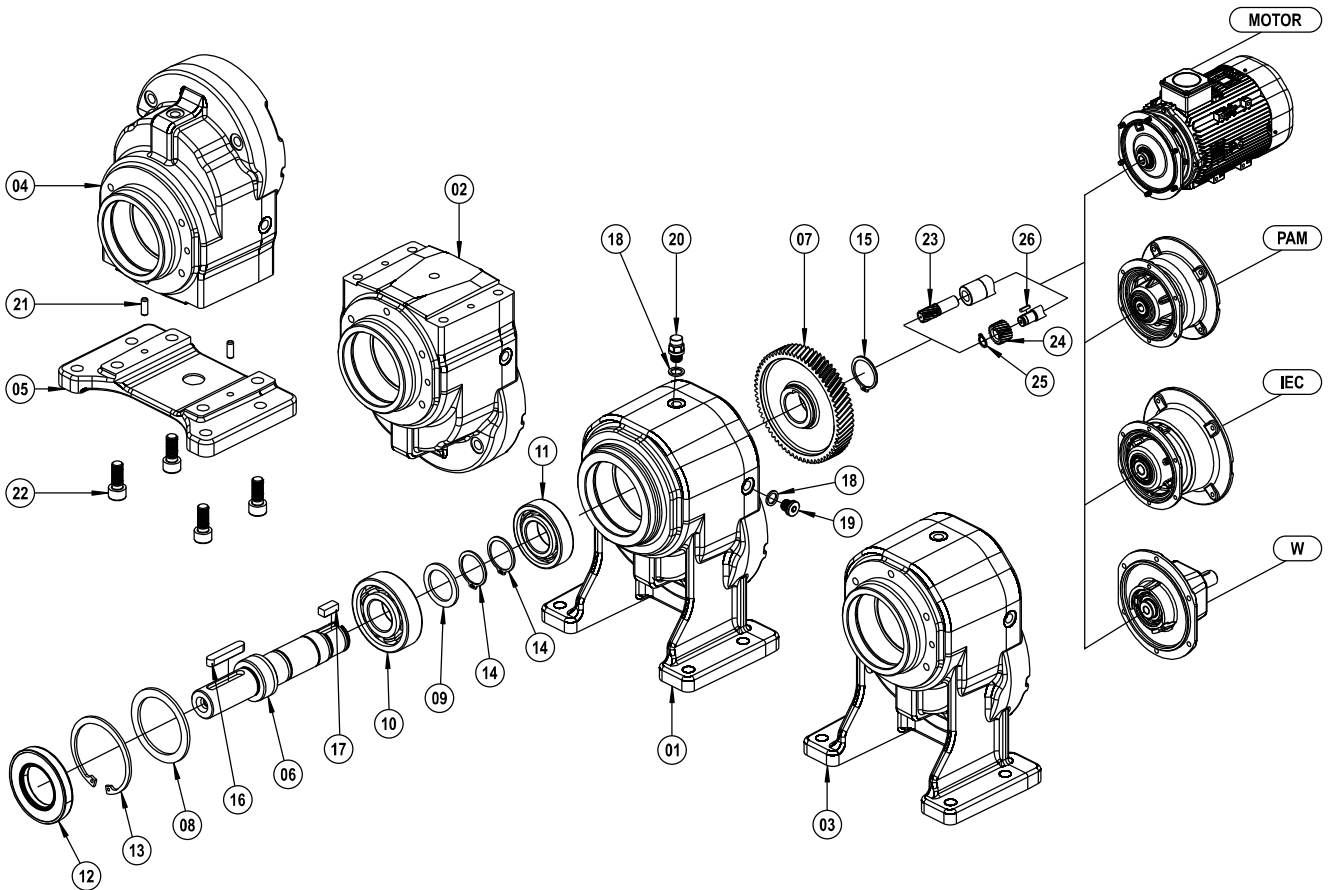

- |                                   |                           |                                  |                              |                               |
|-----------------------------------|---------------------------|----------------------------------|------------------------------|-------------------------------|
| 01 A Gehäuse                      | A Gear Case               | A Ingranaggi Box                 | A Corps                      | A La caja de engranajes       |
| 02 F Gehäuse                      | F Gear Case               | F Ingranaggi Box                 | F Corps                      | F La caja de engranajes       |
| 03 AF Gehäuse                     | AF Gear Case              | AF Ingranaggi Box                | AF Corps                     | AF La caja de engranajes      |
| 04 AF-F-M Gehäuse                 | AF-F-M Gear Case          | AF-F-M Ingranaggi Box            | AF-F-M Corps                 | AF-F-M La caja de engranajes  |
| 05 Fuss                           | Foot                      | Piede                            | Pied                         | Pie                           |
| 06 Abtriebswelle                  | Output Solid Shaft        | Albero di uscita                 | Arbre de sortie              | Eje de salida                 |
| 07 Antriebsrad                    | Driving Gear              | Ingranaggio Conduttore           | Rove d'entrée                | Engranaje con ducido          |
| 08 Distanzscheibe                 | Washer                    | Rondella                         | Rondelle                     | El apoyo a disco              |
| 09 Distanzscheibe                 | Washer                    | Rondella                         | Rondelle                     | El apoyo a disco              |
| 10 Kugellager                     | Bearing                   | Cuscinetto                       | Roulement à billes           | Rodamiento de bolas           |
| 11 Kugellager                     | Bearing                   | Cuscinetto                       | Roulement à billes           | Rodamiento de bolas           |
| 12 Öldichtung                     | Oil Seal                  | Paraolio                         | Joint Huile                  | Sello de aceite               |
| 13 Sicherungsring (DIN 472)       | Circlip (DIN 472)         | Anello di sicurezza (DIN 472)    | Circlip (DIN 472)            | Anillo de seguridad (DIN 472) |
| 14 Sicherungsring (DIN 472)       | Circlip (DIN 472)         | Anello di sicurezza (DIN 472)    | Circlip (DIN 471)            | Anillo de seguridad (DIN 472) |
| 15 Sicherungsring (DIN 471)       | Circlip (DIN 471)         | Anello di sicurezza (DIN 471)    | Circlip (DIN 471)            | Anillo de seguridad (DIN 471) |
| 16 Passfeder (DIN 6885)           | Key (DIN 6885)            | Chiavetta (DIN 6885)             | Clavette (DIN 6885)          | Clave (DIN 6885)              |
| 17 Passfeder (DIN 6885)           | Key (DIN 6885)            | Chiavetta (DIN 6885)             | Clavette (DIN 6885)          | Clave (DIN 6885)              |
| 18 Distanzscheibe (DIN 7603)      | Washer (DIN 7603)         | Rondella (DIN 7603)              | Rondelle (DIN 7603)          | El apoyo a disco (DIN 7603)   |
| 19 Ölstopfel (DIN 908)            | Oil Plug (DIN 908)        | Olio Tappo (DIN 908)             | Couverture d'huile           | Tapón                         |
| 20 Entlüftungstopfen              | Vent Plug                 | Tappo di sfianto                 | Bouchon d'huile (DIN 908)    | Ventilación (DIN 908)         |
| 21 Bolzen                         | Pin                       | Pin                              | Goupille                     | Pasador                       |
| 22 Verschrauben (DIN 912)         | Bolt (DIN 912)            | Bullone (DIN 912)                | Boulonner (DIN 912)          | Atornillar (DIN 912)          |
| 23 Antriebsritzel                 | Driving Pinion            | Ingresso Pignone                 | Engrenage Z1                 | Piñón de entrada              |
| 24 Antriebsritzel (Mit Passfeder) | Driving Pinion (With Key) | Ingresso Pignone (Con chiavetta) | Engrenage Z1 (Avec clavette) | Piñón de entrada (Con clave)  |
| 25 Sicherungsring (DIN 471)       | Circlip (DIN 471)         | Anello di sicurezza (DIN 471)    | Circlip (DIN 471)            | Anillo de seguridad (DIN 471) |
| 26 Passfeder (DIN 6885)           | Key (DIN 6885)            | Chiavetta (DIN 6885)             | Clavette (DIN 6885)          | Clave (DIN 6885)              |

DE ALLGEMEINE TEILELISTE  
FR GÉNÉRALE LA LISTE DES PIÈCES

EN GENERAL PART LIST  
ES LISTE DE PIEZAS EN GENERAL

IT GENERALE ELENCO DELLE PARTI

**AF / F 301 ... 701 / 252 ... 902 / 253 ... 903 - B5**

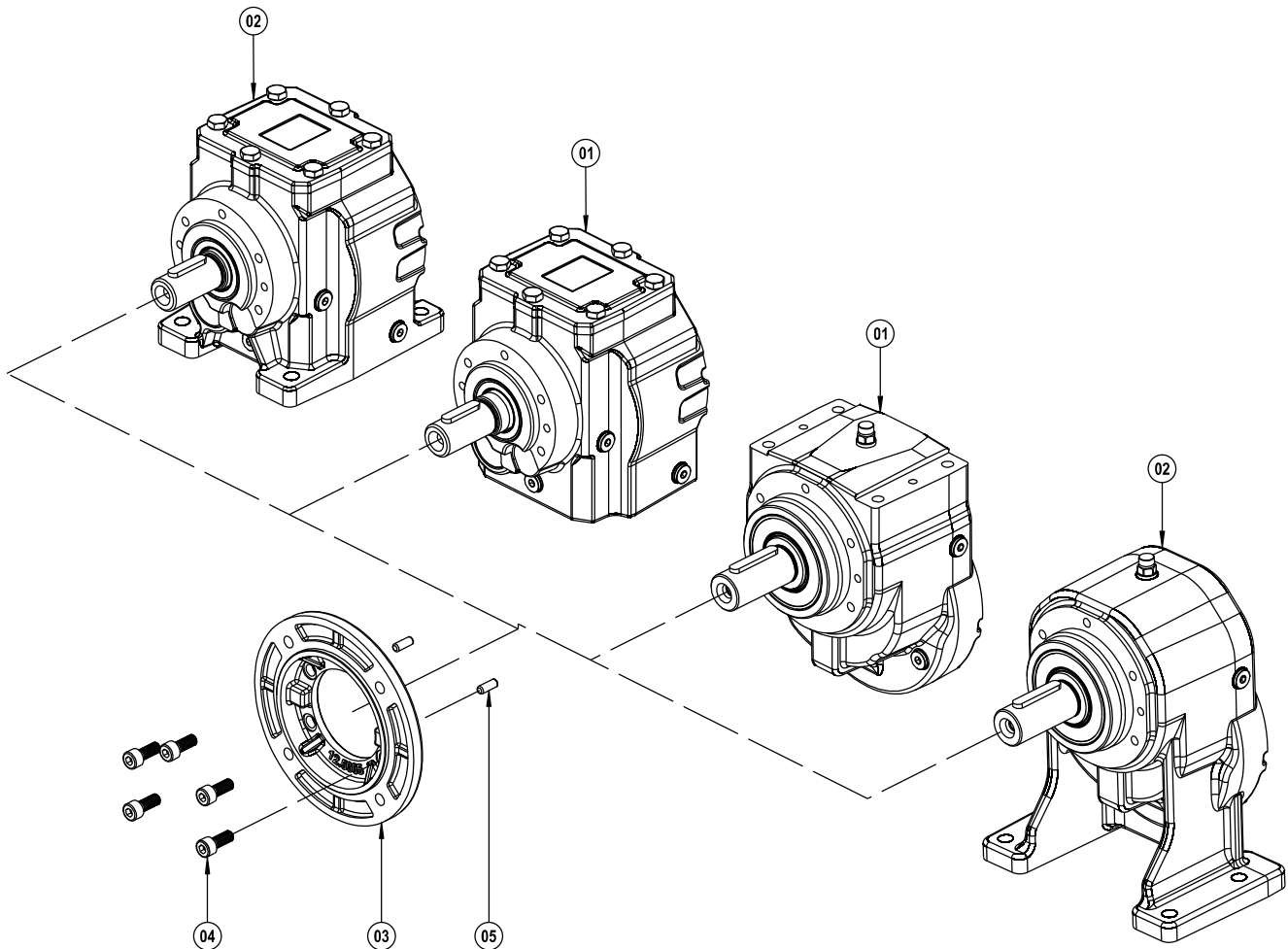

- 01 F Bausatz
- 02 AF Bausatz
- 03 B5 Abtriebsflansch
- 04 Verschrauben (DIN 912)
- 05 Bolzen

- F Kit
- AF Kit
- B5 Output Flange
- Bolt (DIN 912)
- Pin

- F Kit
- AF Kit
- B5 Flangia d'uscita
- Bullone (DIN 912)
- Pin

- F Kit
- AF Kit
- B5 Bride sortie
- Boulonner (DIN 912)
- Goupille

- F Kit
- AF Kit
- B5 Brida de solida
- Atornillar (DIN 912)
- Pasador