

DE PRODUKTE
FR PRODUITS

EN PRODUCTS
ES PRODUCTOS

IT PRODOTTI

A... / MOTOR

Fußbefestigung / Foot mounting / Fissaggio piede /
Fixation à pattes / Fijación por patas

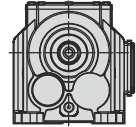
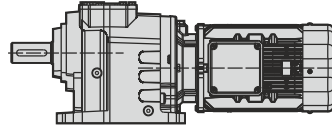

A... / PAM

Fußbefestigung / Foot mounting / Fissaggio piede /
Fixation à pattes / Fijación por patas

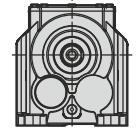
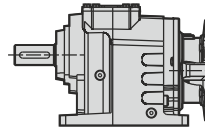

A... / W

Fußbefestigung / Foot mounting / Fissaggio piede /
Fixation à pattes / Fijación por patas

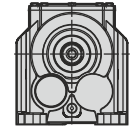
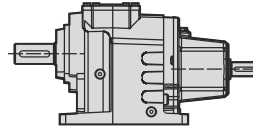

F... / MOTOR

Flanschbefestigung / Flange mounting / Fissaggio flangia /
Fixation à bride / Fijación por brida

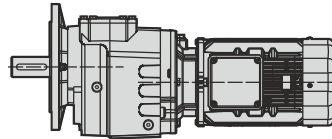

F... / PAM

Flanschbefestigung / Flange mounting / Fissaggio flangia /
Fixation à bride / Fijación por brida

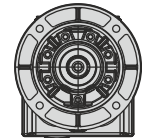
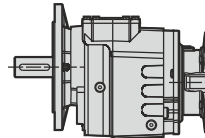

F... / W

Flanschbefestigung / Flange mounting / Fissaggio flangia /
Fixation à bride / Fijación por brida

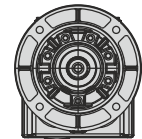
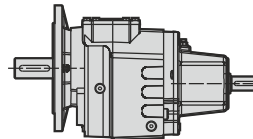

AF... / MOTOR

Fuß-Flanschbefestigung / Foot-flange mounting / Fissaggio piede-flangia
Fixation à paaes et bride / Fijación patas-brida

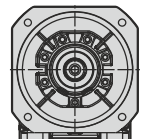
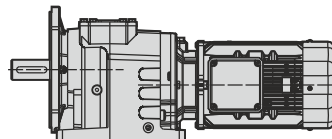

AF... / PAM



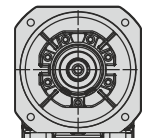
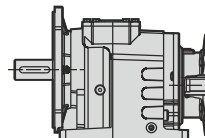



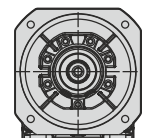
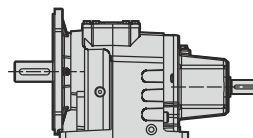

Fuß-Flanschbefestigung / Foot-flange mounting / Fissaggio piede-flangia
Fixation à paaes et bride / Fijación patas-brida



AF... / W

Fuß-Flanschbefestigung / Foot-flange mounting / Fissaggio piede-flangia
Fixation à paaes et bride / Fijación patas-brida



Typ / Type / Tipo Type / Tipo	I _{ges}	4-pol 50Hz 1400rpm n ₂ [min ⁻¹]	M _{amax} f _B =1 4 - pol. [Nm]	W			IEC - PAM							
				P _{1max} 4 - pol. 1400 rpm [kW]	FR1 [kN]	FR2 (a) [kN]	f _B ⇔  49 - 112							
A253	245.76	5.7	200	0.12	1.4	5.5	63*	71*						
F253	197.21	7.1	200	0.15	1.4	5.5	63*	71*						
W	178.56	7.8	200	0.16	1.4	5.5	63*	71*						
	143.29	9.8	200	0.20	1.4	5.5	63	71*						
 119	123.58	11.3	200	0.24	1.3	5.5	63	71*	80*	90*				
+	108.02	13.0	200	0.27	1.3	5.5	63	71*						
PAM - IEC	99.17	14.1	200	0.30	1.3	5.5	63	71*	80*	90*				
	74.76	18.7	200	0.39	1.3	5.5	63	71	80*	90*				
 119	66.56	21.0	200	0.44	1.3	5.5	63	71	80*	90*				
	53.41	26.2	200	0.55	1.3	5.5	63	71	80*	90*				
A252	47.93	29.2	200	0.61	1.3	5.5	71	80*	90*					
F252	42.00	33.3	200	0.70	1.2	5.5	71	80*	90*					
W	38.46	36.4	200	0.76	1.2	5.5	71	80	90*					
	33.38	41.9	200	0.88	1.2	5.5	71	80	90*					
 119	30.15	46.4	200	0.97	1.2	5.3	71	80	90*					
+	26.79	52.3	200	1.09	1.1	5.0	71	80	90*					
PAM - IEC	24.19	57.9	200	1.21	1.1	4.8	71	80	90*					
	23.04	60.8	200	1.27	1.1	4.7	71	80	90*	100*	112*			
 119	20.19	69.3	200	1.45	1.1	4.4	71	80	90*					
	18.49	75.7	200	1.59	1.0	4.2	71	80	90	100*	112*			
	17.05	82.1	190	1.63	1.0	4.1	71	80	90	100*	112*			
	14.91	93.9	170	1.67	1.0	4.1	71	80	90	100*	112*			
	13.94	100.4	170	1.79	1.0	3.9	71	80	90	100*	112*			
	11.97	117.0	145	1.78	1.0	3.9	71	80	90	100*	112*			
	10.32	135.7	140	1.99	0.9	3.7	71	80	90	100*	112*			
	9.02	155.2	130	2.11	0.9	3.6	71	80	90	100*	112*			
	7.93	176.5	125	2.31	0.8	3.4	71	80	90	100*	112*			
	6.36	220.0	105	2.42	0.8	3.3	71	80	90	100*	112*			
	4.80	291.8	95	2.90	0.7	3.0	71	80	90	100*	112*			

Keine IEC - PAM-Verbindung / No IEC - PAM assembling on empty fields / Nessun assemblaggio IEC - PAM su campi vuoti /
Pas d'assemblage IEC - PAM sur champs vides / Sin montaje IEC - PAM en campos vacíos

63 IEC - PAM-Verbindung möglich / IEC - PAM assembling available on numbered fields / Montaggio IEC - PAM disponibile su campi numerati /
Assemblage IEC - PAM disponible sur champs numérotés / Assemblage IEC - PAM disponible sur champs numérotés /

80* Bei IEC - PAM-Verbindungen, sollten die P_{1max}-Werte nicht überschritten werden / Do not exceed the P_{1max} values indicated on fields with asterisk /
Non superare i valori P_{1max} indicati sui campi con l'asterisco / Ne pas dépasser les valeurs P_{1max} indiquées sur les champs avec astérisque /
No exceda los valores de P_{1max} indicados en los campos con asterisco

A 252-253 PAM B5/B14

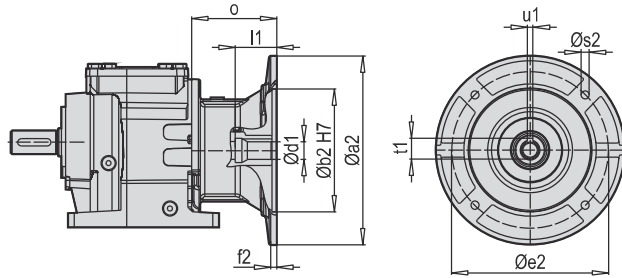

A 252-253 W

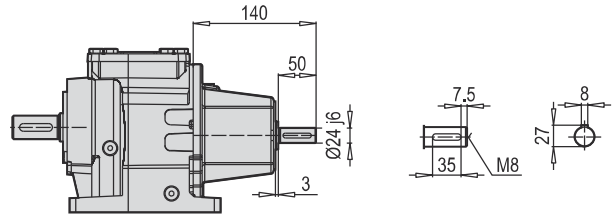

F 252-253 PAM B5/B14

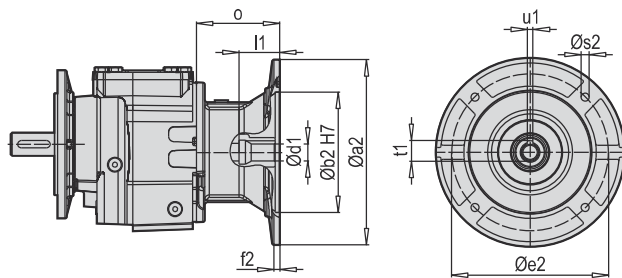

F 252-253 W

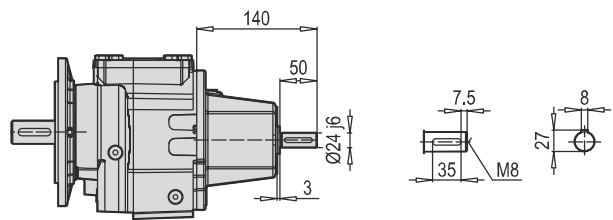

AF 252-253 PAM B5/B14

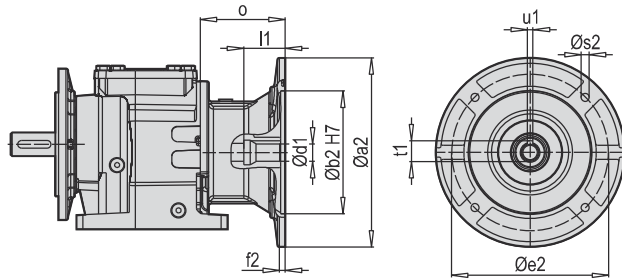

AF 252-253 W

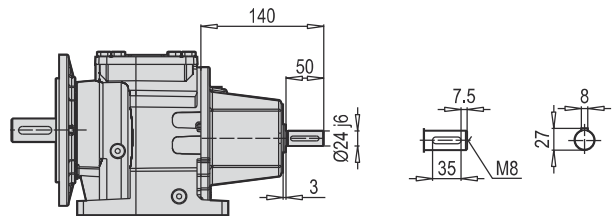

W ~ Kg	
A/F 252 - 253	14

Typ / Type / Tipo Type / Tipo	~ Kg										
	PAM B5	Øa2	Øb2	Øe2	f2	Øs2	Ød1	l1	t1	u1	o
A/F 252 A/F 253	63	140	95	115	4,5	M8	11	25	12,8	4	57
	71	160	110	130	5	M8	14	32	16,3	5	69
	80	200	130	165	5	M10	19	42	21,8	6	90
	90	200	130	165	5	M10	24	52	27,3	8	90
	100	250	180	215	5,5	M12	28	62	31,3	8	105
	112	250	180	215	5,5	M12	28	62	31,3	8	105

~ Kg	
PAM B5	A/F 252 - 253
63	12
71	13
80	14
90	14
100	18
112	18

Typ / Type / Tipo Type / Tipo	~ Kg										
	PAM B14	Øa2	Øb2	Øe2	f2	Øs2	Ød1	l1	t1	u1	o
A/F 252 A/F 253	63	90	60	75	2,5	6	11	25	12,8	4	57
	71	105	70	85	2,5	7	14	32	16,3	5	69
	80	120	80	100	3	7	19	42	21,8	6	90
	90	140	95	115	3	9	24	52	27,3	8	90
	100	160	110	130	3,5	9	28	62	31,3	8	105
	112	160	110	130	3,5	9	28	62	31,3	8	105

~ Kg	
PAM B14	A/F 252 - 253
63	11
71	12
80	13
90	13
100	14
112	14

DE ALLGEMEINE TEILELISTE

EN GENERAL PART LIST

IT GENERALE ELENCO DELLE PARTI

FR GÉNÉRALE LA LISTE DES PIÈCES

ES LISTE DE PIEZAS EN GENERAL

A / F / AF 252 ... 902

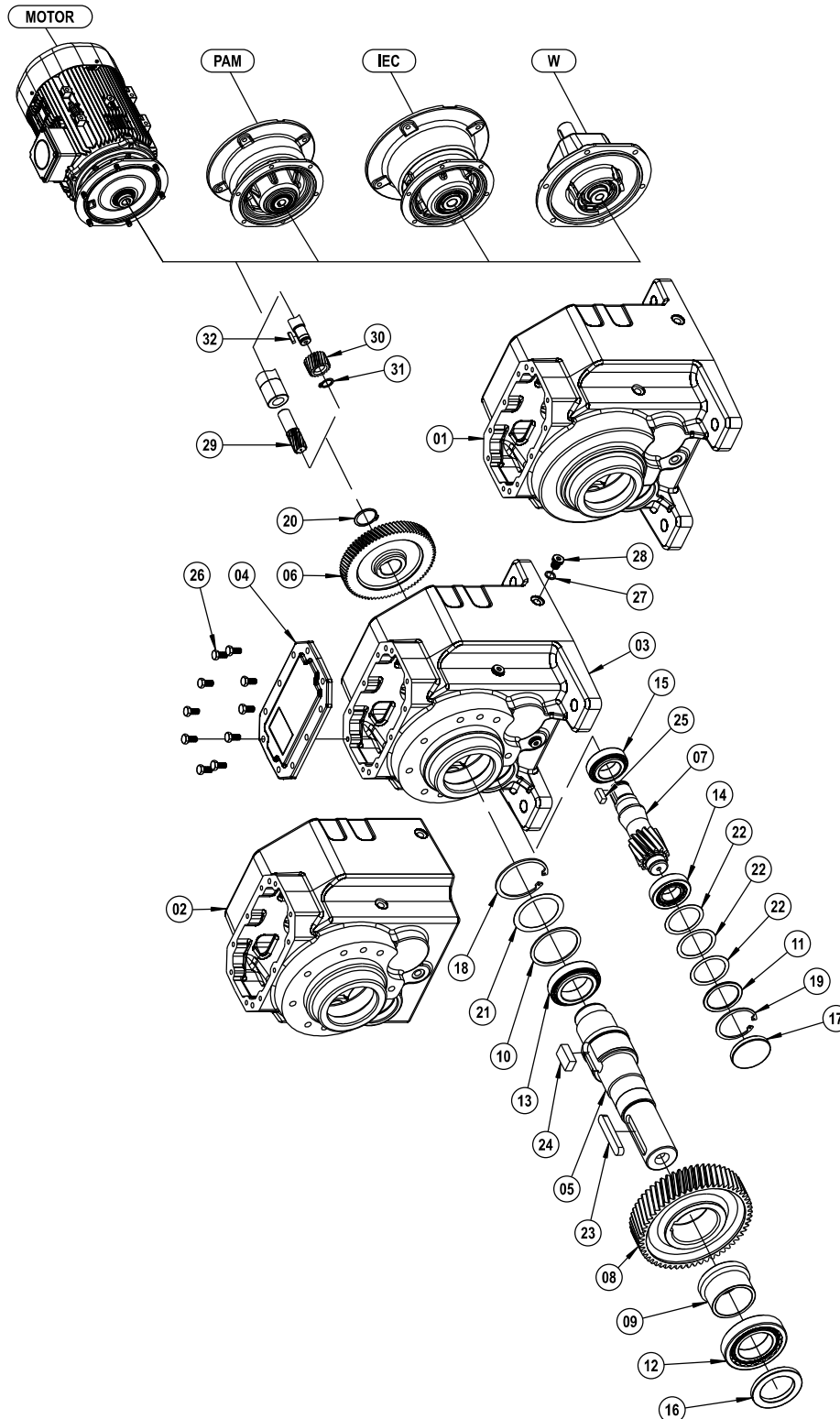

DE

ALLGEMEINE TEILELISTE

EN

GENERAL PART LIST

IT

GENERALE ELENCO DELLE PARTI

FR

GÉNÉRALE LA LISTE DES PIÈCES

ES

LISTE DE PIEZAS EN GENERAL

01 A Gehäuse	A Gear Case	A Ingranaggi Box	A Corps	A La caja de engranajes
02 F Gehäuse	FGear Case	F Ingranaggi Box	F Corps	F La caja de engranajes
03 AF Gehäuse	AF Gear Case	AF Ingranaggi Box	AF Corps	AF La caja de engranajes
04 Abdeckung	Cover	Coperchio	Couverture	Cubierta
05 Abtriebswelle	Output Solid Shaft	Albero di uscita	Arbre de sortie	Eje de salida
06 Antriebsrad	Driving Gear	Ingranaggio Conduttore	Rove d'entrée	Engranaje con ducido
07 Ritzelwelle	Pinion Shaft	Pignone	Arbre intermédiaire	Deleje del piñón
08 Abtriebsrad	Driven Gear	Ingranaggio Condotto	Rove de sortie	Engranaje conducido
09 Distanzbuchse	Spacer	Distanziatore	Bague de réduction	Espaciador
10 Distanzscheibe	Washer	Rondella	Rondelle	El apoyo a disco
11 Distanzscheibe	Washer	Rondella	Rondelle	El apoyo a disco
12 Kugellager	Bearing	Cuscinetto	Roulement à billes	Rodamiento de bolas
13 Kugellager	Bearing	Cuscinetto	Roulement à billes	Rodamiento de bolas
14 Kugellager	Bearing	Cuscinetto	Roulement à billes	Rodamiento de bolas
15 Kugellager	Bearing	Cuscinetto	Roulement à billes	Rodamiento de bolas
16 Öldichtung	Oil Seal	Paraolio	Joint Huile	Sello de aceite
17 Ölbedeckung	Oil Cover	Tappo di chiusura	Couverture d'huile	Tapón de cierre
18 Sicherungsring (DIN 472)	Circlip (DIN 472)	Anello di sicurezza (DIN 472)	Circlip (DIN 472)	Anillo de seguridad (DIN 472)
19 Sicherungsring (DIN 472)	Circlip (DIN 472)	Anello di sicurezza (DIN 472)	Circlip (DIN 472)	Anillo de seguridad (DIN 472)
20 Sicherungsring (DIN 471)	Circlip (DIN 471)	Anello di sicurezza (DIN 471)	Circlip (DIN 472)	Anillo de seguridad (DIN 471)
21 Passscheibe (DIN 988)	Shim (DIN 988)	Shim (DIN 988)	Rondelle d'ajustage (DIN 988)	Calce (DIN 988)
22 Passscheibe (DIN 988)	Shim (DIN 988)	Shim (DIN 988)	Rondelle d'ajustage (DIN 988)	Calce (DIN 988)
23 Passfeder (DIN 6885)	Key (DIN 6885)	Chiavetta (DIN 6885)	Clavette (DIN 6885)	Clave (DIN 6885)
24 Passfeder (DIN 6885)	Key (DIN 6885)	Chiavetta (DIN 6885)	Clavette (DIN 6885)	Clave (DIN 6885)
25 Passfeder (DIN 6885)	Key (DIN 6885)	Chiavetta (DIN 6885)	Clavette (DIN 6885)	Clave (DIN 6885)
26 Verschrauben (DIN 933)	Bolt (DIN 933)	Bullone (DIN 933)	Boulonner (DIN 933)	Atornillar (DIN 933)
27 Distanzscheibe (DIN 7603)	Washer (DIN 7603)	Rondella (DIN 7603)	Rondelle (DIN 7603)	El apoyo a disco (DIN 7603)
28 Ölstopf (DIN 908)	Oil Plug (DIN 908)	Oljo Tappo (DIN 908)	Bouchon d'huile (DIN 908)	Tapón (DIN 908)
29 Antriebsritzel	Driving Pinion	Ingresso Pignone	Engrenage Z1	Piñón de entrada
30 Antriebsritzel (Mit Passfeder)	Driving Pinion (With Key)	Ingresso Pignone (Con chiavetta)	Engrenage Z1 (Avec clavette)	Piñón de entrada (Con clave)
31 Sicherungsring (DIN 471)	Circlip (DIN 471)	Anello di sicurezza (DIN 471)	Circlip (DIN 471)	Anillo de seguridad (DIN 471)
32 Passfeder (DIN 6885)	Key (DIN 6885)	Chiavetta (DIN 6885)	Clavette (DIN 6885)	Clave (DIN 6885)

DE ALLGEMEINE TEILELISTE

EN GENERAL PART LIST

IT GENERALE ELENCO DELLE PARTI

FR GÉNÉRALE LA LISTE DES PIÈCES

ES LISTE DE PIEZAS EN GENERAL

AF / F 301 ... 701 / 252 ... 902 / 253 ... 903 - B5

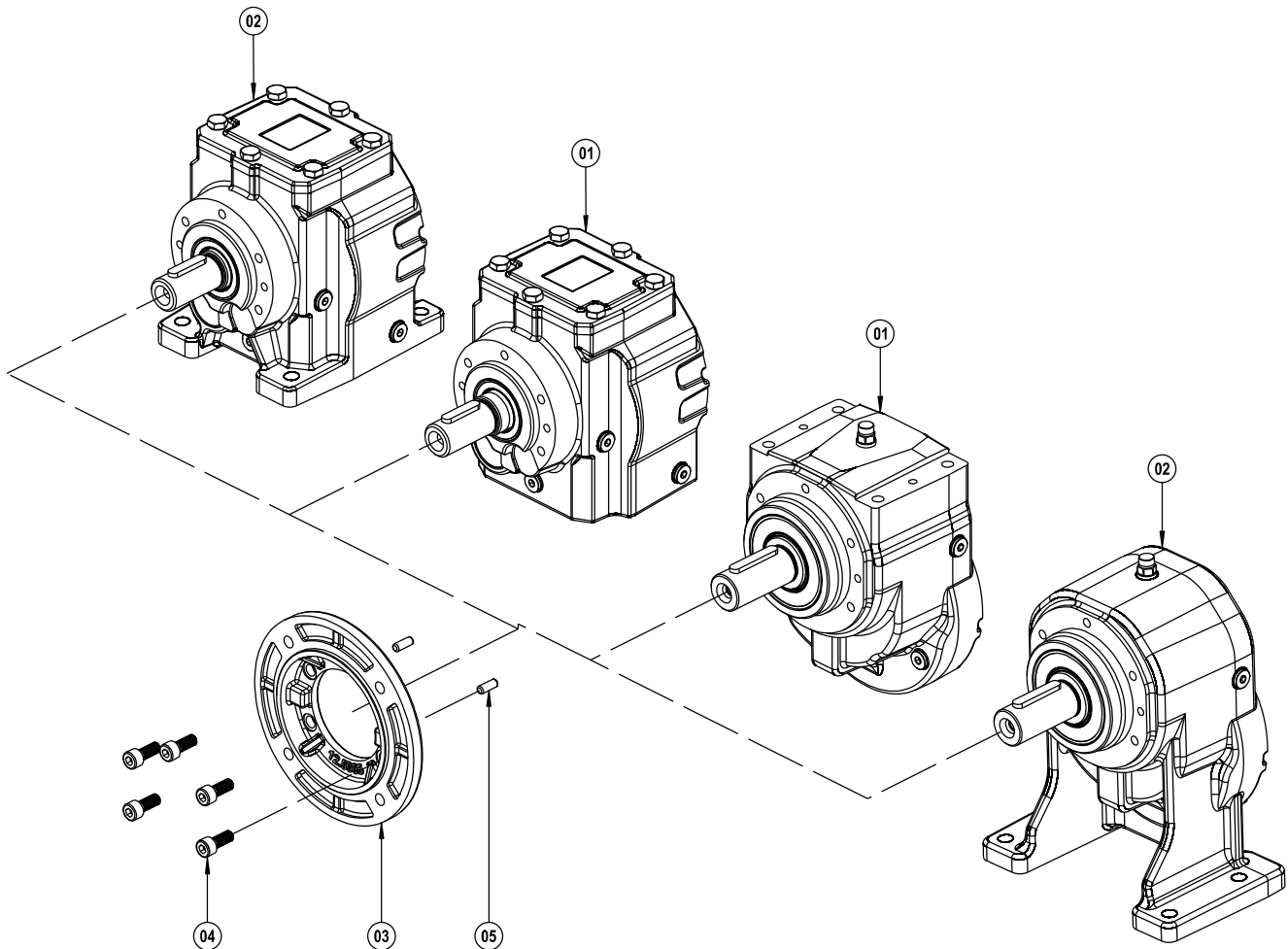

- 01 F Bausatz
- 02 AF Bausatz
- 03 B5 Abtriebsflansch
- 04 Verschrauben (DIN 912)
- 05 Bolzen

- F Kit
- AF Kit
- B5 Output Flange
- Bolt (DIN 912)
- Pin

- F Kit
- AF Kit
- B5 Flangia d'uscita
- Bullone (DIN 912)
- Pin

- F Kit
- AF Kit
- B5 Bride sortie
- Boulonner (DIN 912)
- Goupille

- F Kit
- AF Kit
- B5 Brida de solida
- Atornillar (DIN 912)
- Pasador